



## DisplayPort™ Transmitter IP Core

### For Integration into System-on-Chip Products

DisplayPort™ is the next-generation high-speed display interconnect standard for monitors, notebooks, and consumer electronics. It realizes much higher data transmission throughput than HDMI or DVI using a single interconnect cable, along with better overall system performance, lower cost and improved interoperability.

As provider of the world's first VESA certified discrete DisplayPort transmitter/receiver, Analogix offers its DisplayPort transmitter/receiver IP cores which are fully compliant with the DisplayPort 1.1a specifications. It is ideal for integration into customers' system-on-chip products including PC or PC graphics cards, notebook PCs, monitors, projectors or TVs to drive the internal flat panel display interface. The DisplayPort IP cores are also suitable for typical consumer electronics applications such as optical disc players, set top boxes, and TV displays.

Analogix DisplayPort™ transmitter IP core provides all the signal requirements for the DisplayPort source device receptacle, including Deep Color (up to 36 bits-per-pixel) video modes and S/PDIF digital audio modes. It supports packetized data transmission at 1.62/2.7Gbps over 1/2/4 lanes and WQXGA display solution. The half duplex, bi-directional AUX Channel provides 1Mbps data rate for link configuration and management. The IP core also supports HDCP 1.3 encryption, Hot Plug/Unplug Detect and Built-In Self Test (BIST) functions.

### Applications

- PC Motherboards
- Notebook PCs
- PC Graphics Cards
- Blu-Ray Disc Players

### Typical Application Diagram

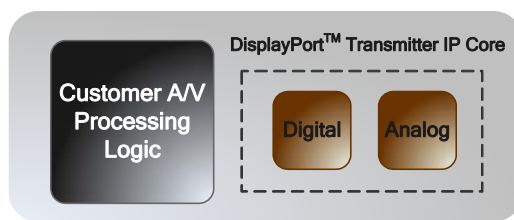

ASIC System-on-chip with  
Integrated DisplayPort™ Transmitter IP Core

### Related IP Cores

- DisplayPort™ Dual-Mode Tx
- HDMI 1.3/1.2 Transmitter/Receiver
- CoolHD™ - Low Power Transmitter
- SERDES (6.25Gbps or less)
- Ethernet PHY

### Features

#### Highlights

- DisplayPort 1.1a with HDCP 1.3
- CTS Certified
- Silicon-proven in TSMC 0.18um process
- 1/2/4 lane operation at 1.62/2.7Gbps per lane
- Spread-spectrum clock (SSC) for EMI suppression and external SSCG interface
- Half-duplex, bi-directional AUX CH with up to 1Mbps bandwidth
- Refresh rate/Display resolution up to WQXGA
- EIA/CEA-861 supported
- Hot Plug/Unplug detect
- Built-In Self Test (BIST)

#### Video Interface

- 24/30/36-bit RGB/YCbCr 4:4:4 (Deep Color)
- 24-bit YCbCr 4:2:2
- 8/10/12-bit YCbCr 4:2:2 (ITU BT-601 and -656)
- LVTTTL and DVO logic levels
- 12/15/18 DDR data modes with up to 36bbp
- Color space conversion and up-/downsample

#### Digital Audio Interface

- Up to 192kHz audio sampling rate
- S/PDIF, 8 Channel I<sup>2</sup>S
- Up to 8 channels audio in/out
- IEC60958 or IEC61937 compatible
- Dolby Digital®, DTS, DVD-Audio and PCM supported

### Block Diagram

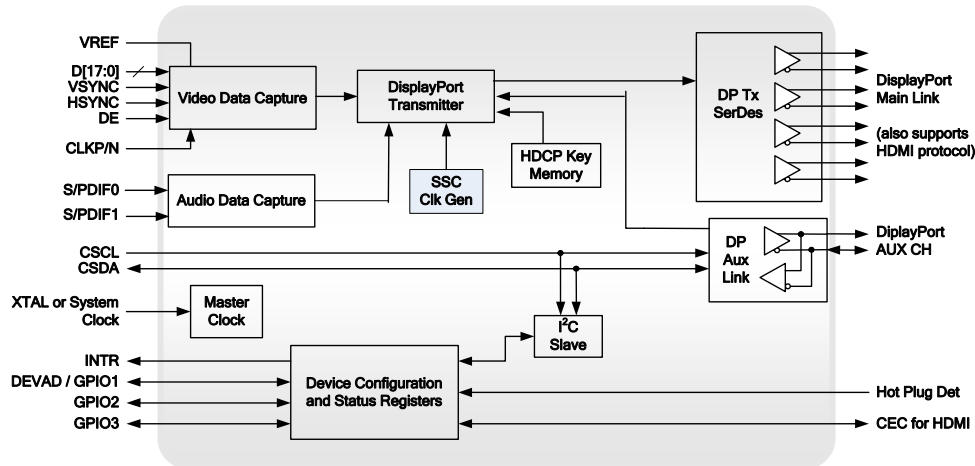

### Worldwide Locations

Analogix is positioned to support customers worldwide with headquarters in Santa Clara, CA and design engineering and product support in Beijing, China. Analogix also has sales support offices in Taiwan and Japan. For more information: [www.analogix.com](http://www.analogix.com).