

## SlimPort® to HDMI® and VGA Adapter

The SP1202 adapter connects SlimPort or MyDP enabled mobile devices to TVs with an HDMI connection, or monitors and projectors with a VGA connection. Capable of Full HD resolutions, the SP1202 displays the content of your mobile device on the big screen for all to share.

### Features

- Video output
  - HDMI 1.4 female connection to TV
  - VGA female connection to projector or monitor
  - Single video output at a time (HDMI has precedence)
  - Supports resolutions up to 1080p @60Hz, 24bpp
  - HDMI 1.4 3D support
  - HDCP 1.3 content protection with HDMI output
  - Audio support only with HDMI output (up to 7.1 channels)
- Standards compliance
  - SlimPort certified
  - VESA MyDP 1.1a compliant
  - HDMI 1.4 compliant
  - FCC Part 15 Class B EMI compliant
  - CE certified
  - RoHS II compliant
  - Halogen free
- Electrical requirements
  - 350mW with VGA output
- CoolHD® with HDMI output
- Optional 5V/1.5A (±10%) fastcharging
- ± 4kV ESD contact
- ± 8kV ESD air
- Other features
  - 400k hours MTBF
  - 1 year guarantee
  - 0 to +45°C operating temperature
  - -5 to +75°C storage temperature
  - 5 to 95% relative humidity
  - 0.1Kg
  - Plug-and-play functionality
- Physical specifications
  - HDMI/VGA molding: 6.23cm \* 4.3cm \* 1.4cm
  - Micro-USB molding: 1.9cm \* 1.08cm \* 0.62cm
  - Color CMYK: black - 10:10:10:100, white - 0:0:0:0, DP Tangerine - 0:80:90:00
  - Length: 15cm
- Package
  - Sealed ESD Protected Plastic Bag
  - 21cm\*16.5cm
  - Bar code identification sticker

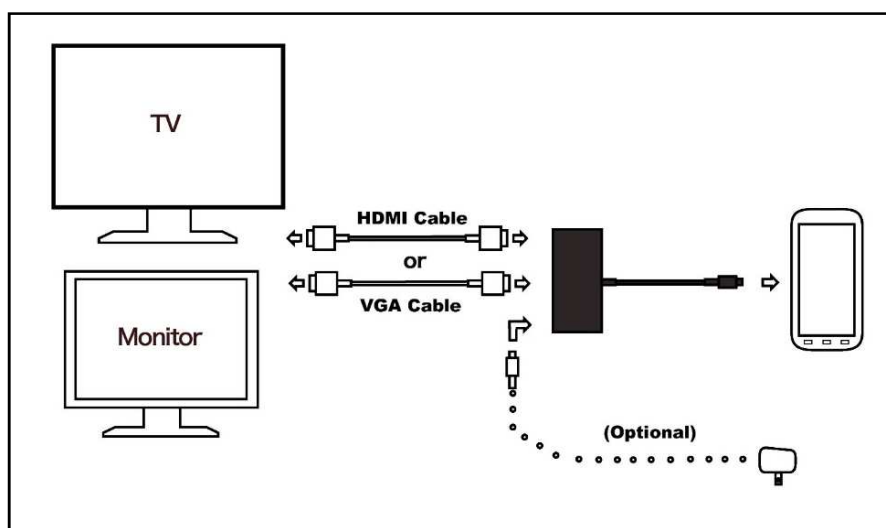

## Ordering Information

| Part Number | Description                      |
|-------------|----------------------------------|
| SP1202      | SlimPort to HDMI and VGA adapter |

## Related Products

| Part Number | Description              |
|-------------|--------------------------|
| SP1004      | SlimPort to HDMI Adapter |
| SP2003      | SlimPort to VGA Adapter  |



Copyright ©2014 Analogix Semiconductor, Inc.  
 3211 Scott Blvd., Suite 103  
 Santa Clara, CA 95054, USA  
 +1(408) 988-8848

<http://www.analogix.com/>

©2014 Analogix Semiconductor, Inc. All Rights reserved.

THE INFORMATION CONTAINED IN THIS DOCUMENT IS PROVIDED "AS IS" WITHOUT ANY EXPRESS REPRESENTATIONS OF WARRANTIES. IN ADDITION, ANALOGIX SEMICONDUCTOR INC. DISCLAIMS ALL IMPLIED REPRESENTATIONS AND WARRANTIES, INCLUDING ANY WARRANTY OF MERCHANTABILITY, FITNESS FOR A PARTICULAR PURPOSE, OR NON-INFRINGEMENT OF THIRD PARTY INTELLECTUAL PROPERTY RIGHTS.

This document contains proprietary information of Analogix Semiconductor, Inc. or under license from third parties. No part of this document may be reproduced in any form or by any means or transferred to any third party without the prior written consent of Analogix Semiconductor, Inc.

The information contained in this document is not designed or intended for use in on-line control of aircraft, aircraft navigation or aircraft communications; or in the design, construction, operation or maintenance of any nuclear facility. Analogix disclaims any express or implied warranty of fitness for such uses.

Analogix Semiconductor, Inc., the Analogix Logo, and WideEye™ SerDes, SlimPort®, and CoolHD® are trademarks of Analogix Semiconductor, Inc., in the United States and other countries.

HDMI, the HDMI logo and High-Definition Multimedia Interface are trademarks or registered trademarks of HDMI Licensing LLC.

DisplayPort and the DisplayPort logo are trademarks or registered trademarks of the Video Electronics Standards Association, VESA®.

USB and the USB logo are trademarks or registered trademarks of USB Implementers Forum, Inc., creators of USB technology.

All other trademarks and registered trademarks are the property of their respective owners.