

10G Active Mux (1x2) with Integrated Re-timer for USB 3.2

ANX7431 is a USB3.2 Gen2 10G active mux with integrated re-timer capable of recovering the USB signals with loss compensation of up to 23dB. ANX7431 also integrates a mux (1x2) for USB Type-C™ (USB-C™) applications. ANX7431 supports Separate Reference Clock Independent SSC (SRIS) and Bit-Level Re-timer (BLR) architectures for a hybrid implementation for Gen 1 and Gen 2. SRIS re-timers eliminate jitter transfer and guarantee Gen 2 operation. Host (source) and device (sink) USB-C data-only applications are fully supported by ANX7431 with built-in intelligent switching. With the intelligent digital switching, ANX7431 ensures the enhanced signals from the re-timers are preserved and outputted over the USB-C connector.

Features

- Built-in re-timer
 - Integrated re-timer for USB 3.2 up to Gen2 @ 10Gbps
 - Supports both Separate Reference Clock Independent SSC (SRIS) and Bit-Level Re-timer (BLR) Architectures of USB 3.2 Specification (Appendix-E)
 - Supports both host (source) and device (sink) applications in USB-C subsystems
 - Loss compensation to recover up to 23dB channel loss
- Integrated mux
 - Digital (1x2) mux switches USB signals and preserves enhanced signal output over USB-C connector
 - Mux control input through I2C commands from external I2C master (or, optionally through FLIP/USB_EN pins)
- Integrated Reference CLK
- Serial and debug interfaces
 - I²C Slave interface, up to 1MHz, for mux and re-timer configuration
- Industry standard compatibility
 - USB 3.2 specification, Appendix E
 - USB Type-C r1.2 specification
 - Intel USB 3.2 Repeater and Active Switch specification
- Low-power design
 - Analog power supply at 1.8V
 - I/O power supply at 1.8V
 - Core power supply at 1.2V
- Package
 - QFN-50, 4.7mm x 6.4mm, 0.90mm Z-height, 0.35mm pin-pitch
- Commercial temperature range of 0C to 70C

Applications

Notebooks, desktops, workstations, servers, docking

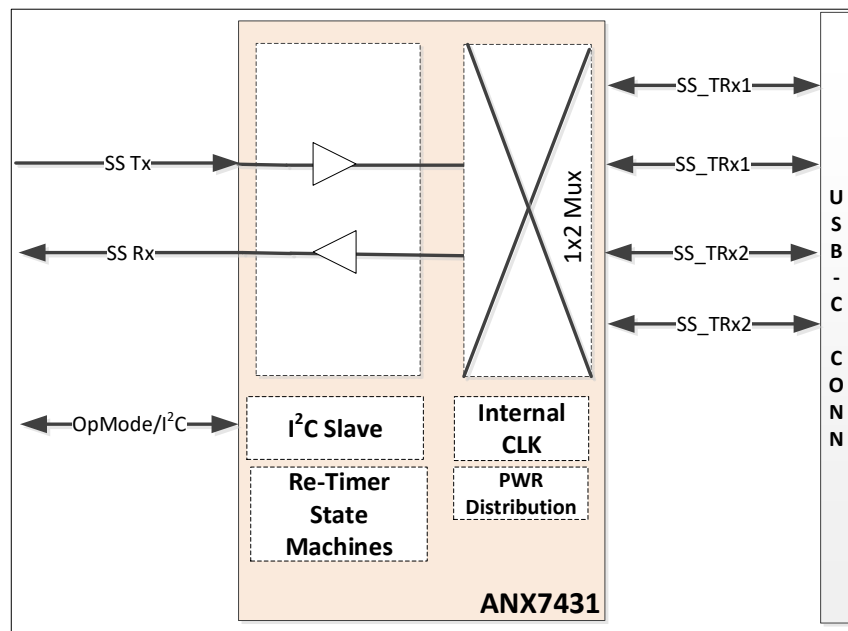

Related Products

Part Number	Description
ANX7433	10G Active Mux (1x2) with Integrated Re-timer and CC Detection for USB 3.2
ANX7443	10G Active Mux (6x4) with Integrated Re-timers for USB3.2/DisplayPort
ANX7451	10G Active Mux (4x4) with Integrated Re-timers for USB3.2/DisplayPort
ANX7491	10G USB 3.2 Re-timer (1-Port)
ANX7497	DisplayPort 4-lane Re-timer

Copyright ©2018 Analogix Semiconductor, Inc.
3211 Scott Blvd., Suite 100
Santa Clara, CA 95054, USA
+1 (408) 988-8848

<http://www.analogix.com/>

©2018 Analogix Semiconductor, Inc. All Rights reserved.

THE INFORMATION CONTAINED IN THIS DOCUMENT IS PROVIDED "AS IS" WITHOUT ANY EXPRESS REPRESENTATIONS OF WARRANTIES. IN ADDITION, ANALOGIX SEMICONDUCTOR INC. DISCLAIMS ALL IMPLIED REPRESENTATIONS AND WARRANTIES, INCLUDING ANY WARRANTY OF MERCHANTABILITY, FITNESS FOR A PARTICULAR PURPOSE, OR NON-INFRINGEMENT OF THIRD PARTY INTELLECTUAL PROPERTY RIGHTS.

This document contains proprietary information of Analogix Semiconductor, Inc. or under license from third parties. No part of this document may be reproduced in any form or by any means or transferred to any third party without the prior written consent of Analogix Semiconductor, Inc.

The information contained in this document is not designed or intended for use in on-line control of aircraft, aircraft navigation or aircraft communications; or in the design, construction, operation or maintenance of any nuclear facility. Analogix disclaims any express or implied warranty of fitness for such uses.

Analogix Semiconductor, Inc., the Analogix Logo, and WideEye™ SerDes, CoolHD™, and SlimPort® are trademarks of Analogix Semiconductor, Inc., in the United States and other countries.

HDMI, the HDMI logo and High-Definition Multimedia Interface are trademarks or registered trademarks of HDMI Licensing LLC.

DisplayPort and the DisplayPort logo are trademarks or registered trademarks of the Video Electronics Standards Association, VESA®.

USB and the USB logo are trademarks or registered trademarks of USB Implementers Forum, Inc., creators of USB technology.

All other trademarks and registered trademarks are the property of their respective owners.